

KANNUR INTERNATIONAL AIRPORT LIMITED

TENDER NOTICE

Sealed item tenders are invited on competitive basis from Suchitwa Mission approved accredited agencies /service providers for supply and installation of pipe compost units and ring compost units at households at Mattannur Municipality , Kannur District under CSR activity of KIAL. The tender application forms can be purchased from the Registered Office, Kannur International Airport Limited,” Parvathy”, TC 36/1,NH Bypass,Chackai,Trivandrum-695024 till 11.00 am on 5 April 2016 or can be downloaded from website www.kannurairport.in. The last date for submission of tender is 3 .00 pm on 15 April 2016.Tenders shall be opened on the same day at 3.30 pm in the presence of available bidders.

Brief Scope of work and other details.

Sl No	Project Name	Nos	Period of Completion	Estimated cost (Rs.)	EMD (Rs.)	Cost of form (Rs.)
1.	Supply & Installation of pipe compost at each household	2500	2 months from the date of work order	76,25,000/-	50,000/-	5000+ VAT
2.	Supply & Installation of ring compost at each house hold	2150	2 months from the date of work order			

All queries/clarifications prior to submission of Tender shall be addressed to managingdirector@kannurairport.in

Eligibility of Applicants

- The tenderers shall be qualified only if they have completed works during last Seven (7) years ending 31.12.2015 as given below:
 - (A) The agency should have completed one similar work of value not less than Rs 61,00,000/- (80 % of estimated cost of work) in a single contract during the last seven years prior to 31.12.2015.
(Phase/ part completion of work in contract shall not be considered)

Or

 - (B) The agency should have completed two similar works of value not less than Rs.38, 12,500/- (50% of estimated cost of work) in a single contract during the last seven years prior to 31.12.2015.
(Phase/ part completion of work in contract shall not be considered)

Or

 - (C) The agency should have completed three similar works of value not less than Rs.22,87,500 /- (30% of estimated cost of work) in a single contract during the last seven years prior to 31.12.2015.
(Phase/ part completion of work in contract shall not be considered).

The tender will be opened at the Registered Office of Kannur International Airport Limited (KIAL), Thiruvananthapuram in the presence of such tenderer or their authorized representatives present at that time. Intending tenderer should quote the rate inclusive of all taxes.

KIAL reserves the right to reject any or all tender without assigning any reason thereof:

- Withdrawals from the tender after it is accepted or failure to execute agreement will entail cancellation of the order forfeiting the EMD and work being entrusted to another firm.
- No representation for enhancement of price once accepted will be considered.
- Any attempt on the part of tenderers or their agents to influence the Officers concerned in their favour by personal canvassing will disqualify the tenderer.
- If any license or permit is required, tenderer must specify it in their tender and also state the authority to which application is to be made.
- The rates quoted should be inclusive of all taxes, duties, cess, loading, unloading etc. which may become payable by the contractor under existing or future laws.
- Payment will be made after performance evaluation by an Officer entrusted by Managing Director, KIAL. Part payment shall be done only on completely installed units.

- Service providers or accredited agencies shall submit a copy proving their recognition from the Govt and the same should be valid at the time of bidding.
- Every tenderer should send along with their tender an EMD amount in the form of separate DD drawn in favour of Kannur International Airport Limited payable at Thiruvananthapuram.
- If Govt. has exempted any firm from furnishing the EMD they should produce relevant documents along with tender.
- Application for the tender form should be accompanied by a cash remittance of cost of tender form with VAT fixed for a form which will not be refunded under any circumstances. Tender forms can be obtained from the KIAL Office Trivandrum on all working days till the date and time specified above. **The cost of tender form shall be in the form of DD drawn in favour of Kannur International Airport Limited payable at Thiruvananthapuram.**
- 5% of the value of the bid will be withheld towards SD which will be released only after 1 year warranty period.
- 90% of the quoted offer only shall be paid by KIAL and 10% of the quoted rate shall be born by the beneficiary for which the agency shall coordinate with Mattannur Municipality
- The utilisation certificate to be obtained by the firm from the house owner duly endorsed by the Mattannur Municipality.
- The equipment should be supplied at each house identified by the Mattannur Municipality.
- All incidental expenditure including cowdung and other expendable items required for completing the unit has to be provided and it is inclusive of the unit cost.
- The agency undertaking the Supply shall also train the beneficiary in operation and capacity building of the unit at the quoted price.
- The Agency should also provide one year free warranty period from the date of installation of the unit during which they shall repair /replace all defective items free of cost.
- The entire facility shall be designed /fabricated /supplied /installed using appropriate technology for the safe use by the beneficiary.

Managing Director

INSTRUCTION TO BIDDERS

The 2(two) part tender consisting of the following and shall be opened simultaneously.

Technical Bid:

1. The Technical Bid would comprise of the following sealed envelopes in a single sealed envelope:
 - i. **Envelop – I:** “Technical Bid” as per Annexure – I & Annexure – II superscripting Name of Bidder, name of Work, , due date of opening of Bid alongwith covering letter at Annexure - III & all relevant documents as mentioned in the tender notice .
 - ii. **Envelop – II:** “Cost of tender document” superscripting Name of Bidder, name of Work, due date of opening of Bid.
 - iii. **Envelop – III:** “Earnest Money Deposit (EMD)” superscripting Name of Bidder, name of Work, due date of opening of Bid.
2. The bidding schedule for submission of Technical Bid is given at tender notice & Para 4 below
3. **Financial Bid:** In sealed cover duly marked by **Envelop-IV** superscripting Name of Bidder, name of Work, due date of opening of Bid.
 - i. The bidding schedule for submission of Financial Bid has been prescribed at Annexure-IV.
 - ii. The Financial Bid shall indicate unit price of the items offered for the project. The unit price shall be written both in figures and words. All pages of the offer to be stamped and signed by the bidders.
 - iii. The offered rate should be firm for supply, installation and commissioning of the complete system comprising of all components as mentioned in the bidding schedule. The Ex-works cost, CST, Excise Duty, cost of Transportation to the sites of installation, Packing, despatching, insurance, taxes & duties, civil constructions etc. shall be covered within the quoted price.
 - iv. **Both the Technical Bid & Financial Bid should be wrapped in a sealed single cover superscripting Name of Bidder, name of Work, due date of opening of Bid etc. and shall be addressed to the Tendering Authority.**
4. **The last date of submission of tender is 3.00 pm on 15 April 2016** and it will be opened, on the same day at 1530 hrs in the presence of the Tenderer or their authorized representative (having valid authorization letter) who may like to be present. In case the day happens to be a holiday, the tenders will be received and opened on the next working day within the specified time.

5. Tender without cost of tender document & EMD will automatically be rejected.
6. Tenders submitted by post should be sent by “Registered Post with acknowledgement due”. These should be posted well in advance to avoid any delay in postal delivery. This office however shall not share any liability for postal delay. Tenders received after the due date of submission shall be liable to be rejected. Tenders received within specified time and date shall only be considered.
7. The undersigned reserves the right to accept/reject any or all the Tenders or part thereof without assigning any reason thereon.

MD , KIAL

TECHNICAL BID

PART-I (a) : COMMERCIAL INFORMATION

1. Name & complete address of the bidder with :
Telephone, mobile, fax nos. & Email etc.
2. Name & designation of the authorized signatory :
to whom reference shall be made
3. Present activities/business of the firm :
4. PAN Card/ VAT/ Sale tax registration :
number (attach copy)
5. Accreditation reference and Copy :

Date
& seal

Signature of bidder

PART I(b): CHECKLIST FOR TENDERER

1. Cost of tender form for Rs 5000/-+ VAT DD No.
(Attached/ not attached.) Date
Name of the Bank:
Payable at
2. EMD for Rs 50,000/- DD No.
(Attached/ not attached.) Date
Name of the Bank:
Payable at
3. Eligibility document, attached or not? Attached / not attached.
4. List Ring compost units and Pipe compost units
supplied, installed & commissioned by the
bidder in last seven financial years (the list
should include the following along with copies Attached / not attached
of concerned work orders) :
(a). Name of Organisation which have awarded
the work

(b) Location of work

(c) Total contact amount

(d) Year of award of work

(e) Details of involvement in the work

(f) Was the work completed satisfactorily within stipulated time

- | | |
|---|--------------------------|
| 5. Credential Certificates, attached or not? | Attached / not attached |
| 6. Literature/ leaflets on products | Attached / not attached |
| 7. Declaration by the Tenderer as per Annexure – II of this Tender document | Attached / Not attached. |

Date

Signature of bidder & seal

(To be given in the letterhead of the bidder)
DECLARATION BY THE TENDERER

(Regarding Tender Notice No. KIAL/CSR/NIT/2015-16/1 dated)

I/We _____ (hereinafter referred to as the Tenderer) being desirous of tendering for the work under the above mentioned tender and having fully understood the nature of the work and having carefully noted all the terms and conditions, specifications etc. as mentioned in the tender document, DO HEREBY DECLARE THAT-

1. The Tenderer is fully aware of all the requirements of the tender document and agrees with all provisions of the tender document.
2. The Tenderer is capable of executing and completing the work as required in the tender.
3. The Tenderer accepts all risks and responsibilities directly or indirectly connected with the performance of the tender.
4. The Tenderer has no collusion with other contractor, any employee of KIAL or with any other person or firm in the preparation of the bid.
5. The Tenderer is financially solvent and sound to execute the work.
6. The Tenderer is sufficiently experienced and competent to perform the contract to the satisfaction of KIAL
7. The information and the statements submitted with the tender are true.
8. The Tenderer has not been debarred or Black Listed from similar type of work by Central / State Government Departments /Undertaking during last three years.
9. This offer shall remain valid for acceptance for 180 days from the date of opening of the tender.
10. The Tenderer has attached herewith the earnest money as required in the tender document.
11. The Tenderer accepts that the earnest money be partially / absolutely forfeited by KIAL as per the terms & conditions laid down in this tender document
12. The Tenderer gives the assurance to execute the tendered work as per specifications, terms and conditions as mentioned in GO (MS) No: 239/2012/LSGD dated 20.09 2012.

(Signature of tenderer)
WITH SEAL

FORMAT FOR COVERING LETTER

ANNEXURE III

From

To

The Managing Director
Kannur International Airport Limited
“Parvathy”, T.C 36/1, NH Bypass, Chackai
Trivandrum-695027

Sir,

I/We hereby tender to carry out the installation of Pipe Compost units and Ring Compost units at households at Mattannur Municipality, Kannur District under the whole of the articles referred and described in the attached specification and schedule, or any portion thereof, as may be decided by the Managing Director, Kannur International Airport Limited (KIAL), at the rates quoted. The installation of Pipe Compost units and Ring Compost units at households will be completed within the time at the places specified in the schedule.

I/We am/are remitting/have separately remitted the required amount of Rs. for the above mentioned work as earnest money.

The tender is submitted in two separate envelopes for technical bid and financial bid along with all the relevant documents as per the tender document.

Signature of the authorized signatory

Name:

Designation

Company Seal

FINANCIAL BID

ANNEXURE IV

Name of the Work : C/O Kannur International Airport - SH- CSR activity by KIAL - Household Solid Waste Treatment within Mattannur Municipality					
Sl No.	Item	No. of Units	Unit Price		Amount in Rs
			In Rupees.	In Words	
1	Supply and Installation of Pipe Composting Unit by taking 2 Pits of 200mm diameter and depth 30cm and fixing two number of ISI Marked PVC pipe of 2.5kgf /cm ² pressure. 200mm diameter 1m long and covering the Pipe with Top Lid cover made out of Ferro cement/Fibre/Gl and as per technical specification enclosed at Annexure V	2500			
2	Supply and Installation of Ring Composting Units with the specification a. Two number of Ferro- cement ring of internal diameter 0.7 m, thickness 2.5 cm and height 0.5 m placed over two circular Ferro- cement slab of dia 0.75 m and thickness 2.5 cm (without fixing). The ring to have a 30cmx30cm opening on the Side at the bottom with a	2150			

1. Pipe Composting Units

Shall be generally design, Manufactured and installed as per the standards of the suchitwa mission

- A single unit will have two units of ISI marked 200mm dia 1m long PVC pipe of 2.5kgf /cm² pressure and air-tight top lid made of Ferro cement/Fibre/GI for and provided with suitable handle for opening and closing of pipe composting unit.
- Erect/fix the pipe vertically inside the pit.
- Activate the mechanization process by sprinkling small quantity of fresh cow-dung mix into the pipe
- Do not pour any liquid waste into it.
- Keep the pipe closed with the lid cover
- Occasionally sprinkle fresh cow- dung or approved inoculums into the waste layer to activate the decomposing process.
- Keep the lid always closed
- Once the pipe is filled up to the top close it and start using the second pipe.
- When the second pipe is filled the first be removed from the pit and push the decomposed waste out by inserting a steel/bamboo rod from the other end
- Decomposed waste has to be dried at shade and used as compost,

The installation of the pipe composting unit shall be made as per the drawing No. 1

All the specifications, standards, unit costs and O&M Protocol, etc should be as per the G.O. (MS) No.239/2012/LSGD dated 29-09-2012.

2. Ring Composting Units

Shall be generally design, Manufactured and installed as per the standards of the suchitwa mission

A single unit will have

- Two number of Ferro- cement ring of internal diameter 0.7 m, thickness 2.5 cm and height 0.5 m placed over two circular Ferro-cement slab of dia 0.75 cm and thickness 2.5 cm (without fixing). The ring to have a 30cmx30cm opening on the Side at the bottom with a Ferro-cement slab cover of the same curved shape which can be removed and refitted back tightly with a locking arrangement for removal of compost when ready. Tile ring will also have a hole of dia 2.5cm at

the bottom for the leachate to now out

- Two number of Circular Ferro- cement cover slab of 0.75 m diameter and 2.5 cm thick with central circular hole of 0.30 cm diameter to cover the ring. The hole will have a lid Cover which can be removed and refitted back for loading the waste into the ring and Closing It tightly after loading the waste
- Compost from bottom when ready
- Remove the top central lid cover of the ring and drop the waste inside the ring
- Spread the waste evenly in within the ring
- Use one ring for the first 90 days and then use the second ring set after filling the first
- After 175 days ,compost from the first ring can be emptied from the side opening and the ring can be further used for further feeding
- Renew the base layer annually

The installation of the ring composting unit shall be made as per the drawing No. 2

All the specifications, standards, unit costs and O&M Protocol, etc should be as per the G.O. (MS) No.239/2012/LSGD dated 29-09-2012.

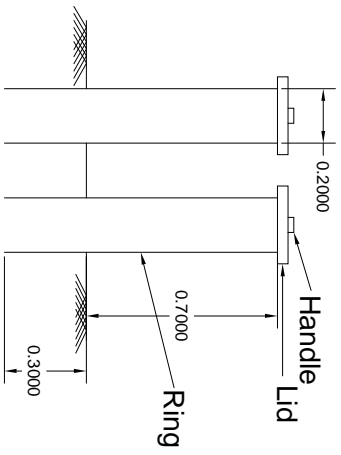

PIPE COMPOSTING

DRG NO.1

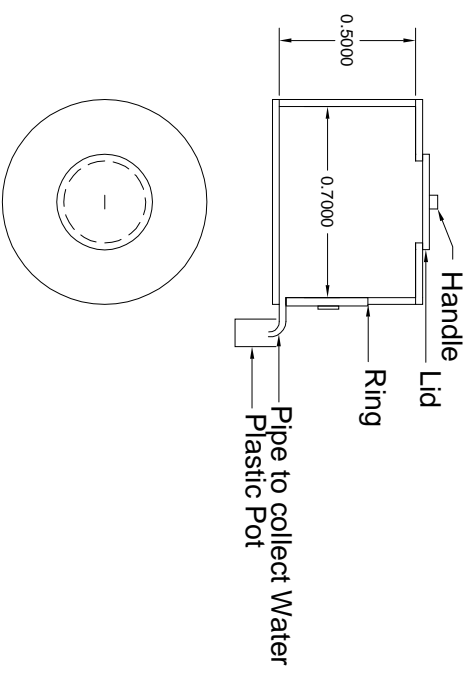
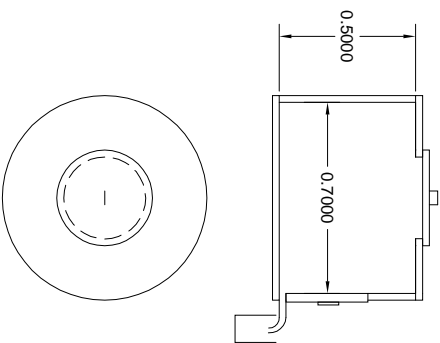

RING COMPOSTING

DRG NO.2